

## **PRODUCT MONOGRAPH**

Pr **TRELSTAR™**

Triptorelin Pamoate for Injectable Suspension

3.75 mg triptorelin (as pamoate) per vial (slow release)  
with Sterile Water for Injection (2mL)

3.75 mg triptorelin (as pamoate) per vial (slow release)  
without Sterile Water for Injection (2mL)

Microgranules for depot suspension

**Luteinizing Hormone-Releasing Hormone (LHRH) Analog**

Watson Laboratories, Inc.  
311 Bonnie Circle  
Corona, CA, USA, 92880

Date of Revision: August 27, 2008

Distributed by:  
Paladin Labs Inc.  
Montreal, QC H4P 2T4

Control No. 120938

Trelstar is a trademark of Watson Laboratories, Inc.

## Table of Contents

<b>PART I: HEALTH PROFESSIONAL INFORMATION</b> .....	<b>3</b>
SUMMARY PRODUCT INFORMATION.....	3
INDICATIONS AND CLINICAL USE .....	3
CONTRAINDICATIONS.....	3
WARNINGS AND PRECAUTIONS .....	4
ADVERSE REACTIONS .....	6
DRUG INTERACTIONS .....	9
DOSAGE AND ADMINISTRATION .....	10
OVERDOSAGE.....	16
ACTION AND CLINICAL PHARMACOLOGY .....	17
STORAGE AND STABILITY .....	19
DOSAGE FORMS, COMPOSITION AND PACKAGING.....	19
<b>PART II: SCIENTIFIC INFORMATION</b> .....	<b>21</b>
PHARMACEUTICAL INFORMATION .....	21
CLINICAL TRIALS .....	21
DETAILED PHARMACOLOGY .....	23
TOXICOLOGY.....	24
REFERENCES.....	25
<b>PART III: CONSUMER INFORMATION</b> .....	<b>28</b>

**Pr TRELSTAR™**  
Triptorelin Pamoate for Injectable Suspension

**PART I: HEALTH PROFESSIONAL INFORMATION**

**SUMMARY PRODUCT INFORMATION**

<b>Route of Administration</b>	<b>Dosage Form / Strength</b>	<b>Clinically Relevant Nonmedicinal Ingredients</b>
Intramuscular	Powder (microgranules) for slow release suspension 3.75 mg of triptorelin peptide base units/vial	<i>For a complete listing see Dosage Forms, Composition and Packaging section.</i>

**INDICATIONS AND CLINICAL USE**

TRELSTAR™ (triptorelin pamoate for injectable suspension) is indicated for:

- The management and relief of chronic pain associated with endometriosis.

TRELSTAR™ must be administered under the supervision of a physician.

Experience in women has been limited to women 18 years of age or older treated for 6 months.

**Geriatrics (>65 years of age):** No data are available.

**Pediatrics (<18 years of age):** Safety and effectiveness of TRELSTAR™ in women with endometriosis under the age of 18 years have not been established.

**CONTRAINDICATIONS**

- TRELSTAR™ is contraindicated in patients with hypersensitivity to gonadotropin releasing hormone or luteinizing hormone-releasing hormone (GnRH or LHRH), GnRH agonist analogs or any ingredient in the formulation or component of the container. Anaphylactic reactions to synthetic GnRH or GnRH agonist analogs have been reported (see WARNINGS AND PRECAUTIONS and Post-Market Adverse Drug Reactions). For a complete listing, see the Dosage Forms, Composition and Packaging sections of the Product Monograph.
- TRELSTAR™ is contraindicated in women who are or may become pregnant while receiving the drug. TRELSTAR™ may cause fetal harm when administered to a pregnant woman. If this drug is used during pregnancy or if the patient becomes pregnant while taking this drug,

she should be apprised of the potential hazard to the fetus (See WARNINGS AND PRECAUTIONS section).

- TRELSTAR™ is contraindicated in nursing women (See WARNINGS AND PRECAUTIONS section).
- TRELSTAR™ is contraindicated in women with undiagnosed abnormal vaginal bleeding.

## **WARNINGS AND PRECAUTIONS**

### **General**

During the early phase of therapy, sex hormones usually rise above baseline levels because of the physiologic effect of the drug. An increase in clinical signs and symptoms of endometriosis is often observed during the initial days of therapy. These will subside with continued treatment.

Worsening of the clinical condition may occasionally require discontinuation of therapy.

Hypersensitivity and anaphylactic reactions have been reported with triptorelin as with other LHRH agonists. TRELSTAR™ should not be administered to individuals who are hypersensitive to triptorelin, other LHRH agonists, or LHRH (see Post-Market Adverse Drug Reactions). In the event of a hypersensitivity reaction, TRELSTAR™ therapy should be discontinued immediately and the appropriate supportive and symptomatic care should be administered.

Before initiating treatment with TRELSTAR™, pregnancy must be ruled out (see Special Population – Pregnant Women).

Retreatment cannot be recommended since safety data beyond 6 months are not available.

### **Carcinogenesis and Mutagenesis**

Carcinogenicity and mutagenicity studies have been performed in animals (see TOXICOLOGY section).

### **Endocrine and Metabolism**

**Changes in Bone Mineral Density:** Bone loss can be expected as part of natural aging and can also be anticipated during the hypoestrogenic state caused by long-term use of triptorelin. Some of the bone density loss over the course of triptorelin therapy may not be reversible. For a period up to 6 months, this bone loss should not be important.

In patients with significant risk factors for decreased bone mineral content and/or bone mass such as family history of osteoporosis, chronic use of corticosteroids or anticonvulsants or chronic use of alcohol or tobacco, triptorelin may pose additional risk. In these patients, risk versus benefit must be weighted carefully before initiation of triptorelin therapy. Repeated courses of therapy with gonadotropin-releasing hormone analogs beyond 6 months are not advisable for patients with major risk factors for loss of bone mineral content.

Long-term administration of triptorelin will cause suppression of pituitary gonadotropins and gonadal hormone production with clinical symptoms of hypogonadism. These changes have been observed to reverse on discontinuation of therapy. However, whether the clinical symptoms of induced hypogonadism will reverse in all patients has not yet been established.

### **Genitourinary**

**Vaginal Bleeding:** Since menstruation should stop with effective doses of TRELSTAR™, the patient should notify her physician if regular menstruation persists. Patients missing successive doses of TRELSTAR™ may experience breakthrough bleeding.

### **Renal and Hepatic**

Triptorelin exposure was higher in patients with renal or hepatic insufficiency than in healthy volunteers. Clinical consequences of the increase and potential need for dose adjustment are unknown.

### **Sexual Function/Reproduction**

**Ovarian Cysts:** As with other drugs that stimulate the release of gonadotropin or that induce ovulation, ovarian cysts have been reported to occur, usually within the first 2 months of treatment. In most cases, these enlargements resolve spontaneously in 4 to 6 weeks. However, in some cases they may require discontinuation of drug and/or surgical intervention.

### **Special Populations**

**Pregnant Women:** The safe use of triptorelin during pregnancy has not been established clinically (see Adverse Reactions section). Before starting therapy with TRELSTAR™, pregnancy must be excluded. When used regularly and at therapeutic doses, TRELSTAR™ inhibits ovulation and subsequently menstruation. However, contraception cannot be insured. Women should use nonhormonal methods of contraception while on therapy and should be advised to see their physician if they think they may be pregnant. If a woman becomes pregnant while receiving TRELSTAR™, therapy should be discontinued and the patient advised of the potential risk to the fetus. The possibility exists that spontaneous abortion may occur if the drug is administered during pregnancy.

**Nursing Women:** It is not known to what extent TRELSTAR™ is excreted into human milk. Because there are no well-controlled studies on the effect of TRELSTAR™ in nursing women and because many drugs are excreted into human milk, caution should be exercised when TRELSTAR™ is administered to nursing women. (See CONTRAINDICATIONS section)

**Pediatrics (< 18 years of age):** Safety and effectiveness of TRELSTAR™ in women with endometriosis under the age of 18 years have not been established.

**Race:** The effects of race on triptorelin pharmacokinetics, safety, and efficacy have not been systematically studied. The controlled study comparing triptorelin [3.75 mg] and leuprolide [3.75 mg] administered monthly for 6 months to endometriosis patients included 97.1% Caucasian, 2.2% Asian, and 0.7% Afro-Caribbean patients.

### **Monitoring and Laboratory Tests**

Before starting therapy with TRELSTAR™, pregnancy must be excluded.

## **ADVERSE REACTIONS**

### **Adverse Drug Reaction Overview**

Triptorelin has been found to be generally well tolerated in clinical trials. Adverse reactions reported in these trials were rarely severe enough to result in patient withdrawal from triptorelin treatment. Three postmarketing reports of anaphylactic shock and seven postmarketing reports of angioedema related to triptorelin administration have been reported since 1986 (see WARNINGS AND PRECAUTIONS). In a controlled study comparing triptorelin [3.75 mg] and leuprolide [3.75 mg] administered monthly for 6 months to endometriosis patients, one case of severe acute abdominal pain was judged probably related to therapy.

As seen with other LHRH agonist therapies, the most commonly observed adverse events during triptorelin treatment were due to the expected physiological effects related to hypoestrogenism. These effects included hot flashes, vaginal dryness, and amenorrhea. During the first 1-2 weeks following the initial injection, estradiol levels increase and then decline to menopausal levels. The transient increase in estradiol levels may be associated with temporary worsening of signs and symptoms of endometriosis (See WARNINGS AND PRECAUTIONS section).

Triptorelin 3.75 mg was found to be generally safe and well tolerated in women with endometriosis treated for up to 6 months with the drug. Most adverse reactions did not result in discontinuation and most resolved spontaneously without further medical intervention. The most frequently reported adverse reactions were those related to hypoestrogenism.

A small number of women have been inadvertently exposed to triptorelin during pregnancy. Of 28 pregnant women in France exposed to triptorelin in fertility trials, one case of trisomy 13 was reported in a woman who received triptorelin 15 days after conception. One case of trisomy 18 has been reported in Italy. In both cases, a causal relationship could not be established. In another study, very long fetal exposure to triptorelin in a woman who became pregnant during a clinically-induced pseudomenopause resulted in the term delivery of a healthy newborn.

## **Clinical Trial Adverse Drug Reactions**

*Because clinical trials are conducted under very specific conditions the adverse reaction rates observed in the clinical trials may not reflect the rates observed in practice and should not be compared to the rates in the clinical trials of another drug. Adverse drug reaction information from clinical trials is useful for identifying drug-related adverse events and for approximating rates.*

In a controlled study comparing triptorelin [3.75 mg] and leuprolide [3.75 mg] administered monthly for 6 months to endometriosis patients, the following adverse events were reported by 1% or more of patients in the triptorelin study group regardless of relationship or association to treatment:

<b>TABLE 1: ADVERSE EVENTS REPORTED BY 1% OR MORE OF PATIENTS DURING TREATMENT WITH TRIPTORELIN</b>	
<b>Adverse Event</b>	<b>Triptorelin (n=67) % of patients</b>
<b>Body As A Whole</b>	
Ankle edema (edema dependent)	23.9
Pain, nos*	11.9
Back pain	9.0
Accidental injury	7.5
Bruising	6.0
Fatigue	3.0
<b>Central and Peripheral Nervous System Disorders</b>	
Headache	59.7
Dizziness	6.0
<b>Endocrine Disorders</b>	
Breast disorder	31.3
<b>Gastrointestinal Disorders</b>	
Nausea	13.4
Abdominal pain	10.4
Vomiting	3.0
<b>Musculoskeletal Disorders</b>	
Arthralgia	7.5

(Continued)

<b>TABLE 1: ADVERSE EVENTS REPORTED BY 1% OR MORE OF PATIENTS DURING TREATMENT WITH TRIPTORELIN (CONTINUED)</b>	
<b>Adverse Event</b>	<b>Triptorelin (n=67) % of patients</b>
<b>Psychiatric</b>	
Insomnia	68.7
Depression	56.7
Decreased libido	53.7
Irritability	44.8
<b>Reproductive Disorders</b>	
Vaginal dryness	49.3
Pelvic pain	3.0
<b>Resistance Mechanism Disorders</b>	
Viral infection	13.4
<b>Skin and Appendages Disorders</b>	
Increased sweating	85.1
Seborrhea	43.3
Acne	29.9
<b>Urinary System</b>	
Urinary tract infection	6.0
<b>Vascular (extracardiac) Disorders</b>	
Hot flushes	91.0

Dose of drug administered was 3.75 mg IM every four weeks for six months (6 injections).

\*nos = not otherwise specified

Frequently reported adverse events for both the triptorelin and leuprolide groups included hot flushes, depression, irritability, headache, breast disorder, arthralgia, insomnia, decreased libido, acne, seborrhea, increased sweating, and vaginal dryness.

Infrequent (<5% of women) adverse events included, but were not limited to, injection site reaction, chest pain, rash, peripheral edema, leg cramps, diarrhea, irritable bowel, arthritis, arthrosis, myalgia, amnesia, apathy, leukorrhea, and vaginal hemorrhage.

*Changes in Bone Mineral Density:* After 6 months of treatment with triptorelin in 32 women, the average decrease in bone mineral density, as measured by dual energy x-ray absorptiometry, was 5.3% and 2.3% in lumbar spine and hip, respectively, compared to pretreatment values. Lumbar spine and hip bone mineral density were still slightly decreased by 12 months follow-up (1.7% and 1.3%, respectively).

### **Abnormal Hematologic and Clinical Chemistry Findings**

For the most part, hematology test results were within normal limits throughout the study for patients in each treatment group with available data. Minor fluctuations in values were observed

at various time points in each of the treatment groups, none of which were considered clinically meaningful. With the exception of serum and urine creatinines, which were relatively low throughout the study, chemistry results were generally within normal limits for most patients throughout the study.

### **Post-Market Adverse Drug Reactions**

Three postmarketing reports of anaphylactic shock and seven postmarketing reports of angioedema related to triptorelin administration have been reported since 1986 (see WARNINGS AND PRECAUTIONS).

## **DRUG INTERACTIONS**

### **Overview**

No formal drug interaction studies have been conducted with TRELSTAR™ and no data are available on the interaction with alcohol. In the absence of relevant data and as a precaution, hyperprolactinemic drugs would not be prescribed concomitantly with triptorelin since hyperprolactinemia reduces the number of pituitary GnRH receptors.

### **Drug-Drug Interactions**

Interactions with other drugs have not been established.

### **Drug-Food Interactions**

Interactions with food have not been established.

### **Drug-Herb Interactions**

Interactions with herbal products have not been established.

### **Drug-Laboratory Interactions**

Administration of LHRH analogs, including triptorelin, in therapeutic doses results in suppression of the pituitary-gonadal system. Normal function is usually restored within 4 to 12 weeks after treatment is discontinued. Diagnostic tests of pituitary-gonadal function conducted during treatment and within 4 to 12 weeks after discontinuation of therapy with a LHRH agonist may therefore be misleading.

In clinical trials, there were no clinically meaningful changes in laboratory values during or following triptorelin therapy. Triptorelin therapy had no significant effect on liver enzymes (ALT/AST), alkaline phosphatase, LDH, total bilirubin, urea or inorganic phosphorous during the study. Likewise, there was no significant treatment effect on hematology parameters (WBC, RBC, hemoglobin, hematocrit, platelet count, or WBC differential).

## **DOSAGE AND ADMINISTRATION**

### **Recommended Dose and Dosage Adjustment**

The recommended dose of TRELSTAR™ (triptorelin pamoate for injectable suspension) for the management and relief of chronic pain associated with endometriosis is a monthly intramuscular injection of 3.75 mg (as peptide base) incorporated in a depot formulation every 28 days for no longer than 6 months.

### **Administration**

TRELSTAR™ is administered monthly as a single intramuscular injection.

### **Missed Dose**

Maintaining estradiol suppression is important in the management and relief of chronic pain associated with endometriosis. Missing an appointment by a few days should not disrupt the benefits of treatment, but keeping a consistent schedule of TRELSTAR™ injections is an important part of treatment.

### **Reconstitution**

TRELSTAR™ is supplied in a single-dose vial containing lyophilized microgranules. These microgranules are to be reconstituted with 2 mL of sterile water for injection. Instructions are provided (see below) for reconstitution using the TRELSTAR™ dose delivery system (with Sterile Water for Injection), Clip'n'Ject®; the TRELSTAR™ dose delivery system (with Sterile Water for Injection), MIXJECT; and the TRELSTAR™ vial (without Sterile Water for Injection).

When 2 mL of Sterile Water for Injection is added to the lyophilized triptorelin pamoate microgranules and mixed, a suspension is formed. This is equivalent to 3.75 mg of triptorelin peptide base units intended as a single monthly intramuscular injection.

The suspension should be discarded if not used immediately after reconstitution. As with other drugs administered by intramuscular injection, the injection site should be varied periodically.

As with all parenteral admixtures, the reconstituted product should be examined for the presence of foreign particulate matter, agglomeration or discoloration. Any defective units should be discarded.

Single use only. Inject immediately after reconstitution and discard unused portion.

**Instructions for Use – TRELSTAR™ Dose Delivery System (with Sterile Water for Injection), Clip'n'Ject®**

Please read complete instructions before you begin.

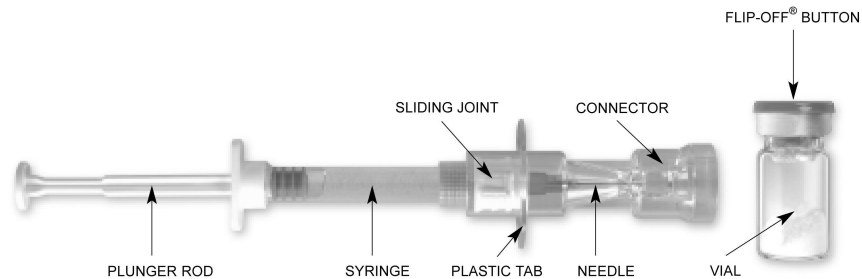

**Clip'n'Ject® Preparation**

Wash your hands with soap and hot water and put on gloves immediately prior to preparing the injection. Place the package containing the Clip'n'Ject system and the Trelstar® vial on a clean, flat surface that is covered with a sterile pad or cloth. Peel the Tyvek® cover away from the blister package, and place the vial, connector, alcohol swab, and plunger rod on the prepared surface. Be sure to begin by removing the Flip-Off® button from the top of the vial, revealing the rubber stopper. Disinfect the rubber portion of the vial cap with the alcohol swab. Discard the alcohol swab and let the alcohol dry. Proceed to Clip'n'Ject Activation.

## Clip'n'Ject® Activation

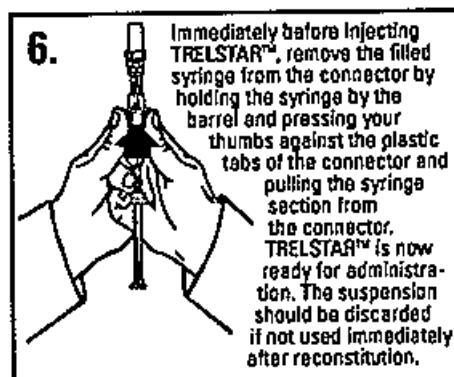
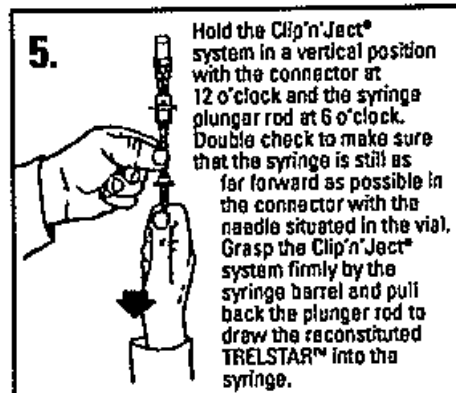
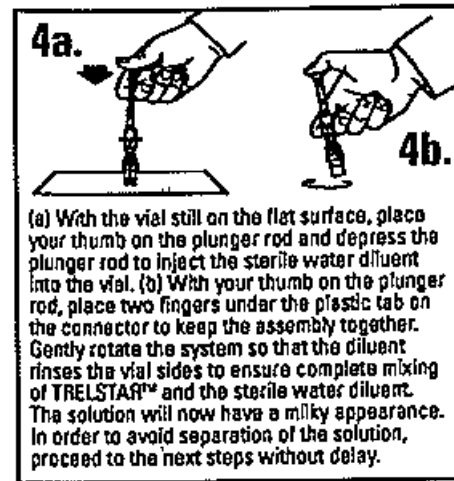
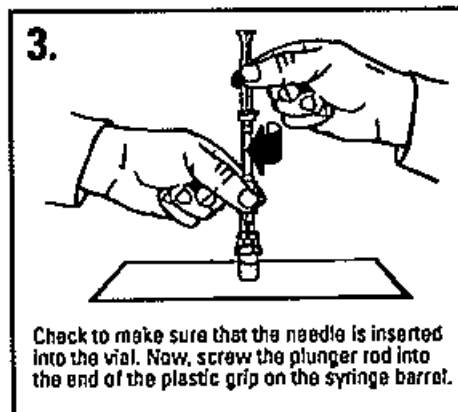
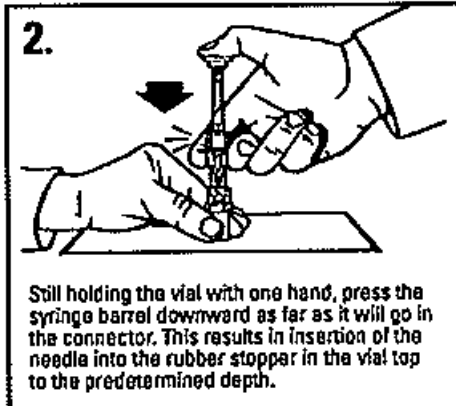
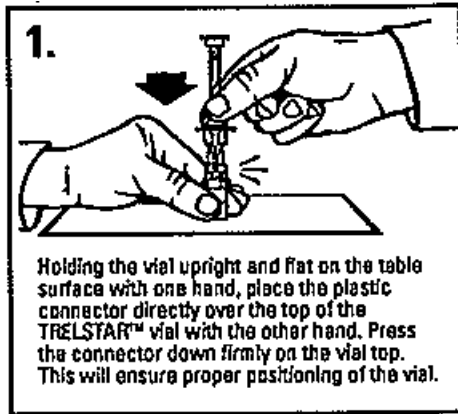

## Clip'n'Ject® Disposal

After administering TRELSTAR™, dispose of the Clip'n'Ject system as follows:

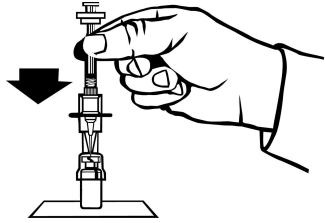

- Place Clip'n'Ject with attached vial in standing upright position on a flat surface.
- Using one hand, replace the syringe into the Clip'n'Ject connector.
- Dispose of syringe and attached Clip'n'Ject connector with vial into a suitable sharps container.

## Instructions for Use – TRELSTAR vial (with Sterile Water for Injection), MIXJECT™:

**Please read the instructions completely before you begin.**

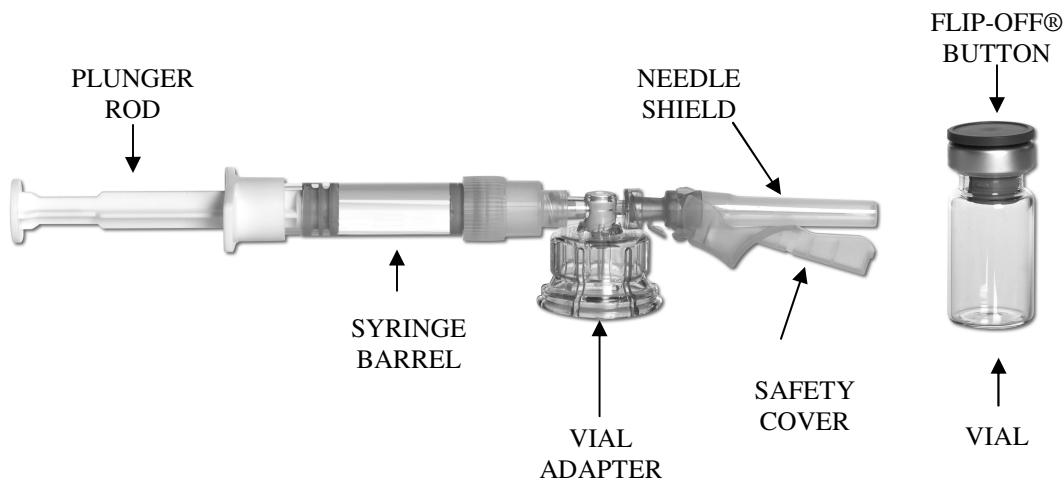

## MIXJECT™ Preparation

Wash your hands with soap and hot water and put on gloves immediately prior to preparing the injection. Place the sealed tray on a clean, flat surface that is covered with a sterile pad or cloth. Peel the cover away from the tray and remove the MIXJECT™ components and the TRELSTAR® vial. Remove the Flip-Off® button from the top of the vial, revealing the rubber stopper. Place the vial in a standing upright position on the prepared surface. Disinfect the rubber

stopper with the alcohol wipe. Discard the alcohol wipe and allow the stopper to dry. Proceed to *MIXJECT™ Activation*.

## MIXJECT™ Activation

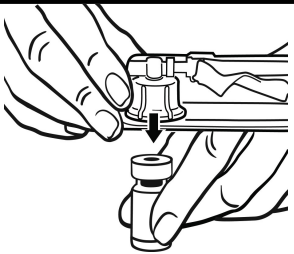
**1.** 

Peel the cover away from the blister pack containing the vial adapter. *Do not remove the vial adapter from the blister pack.* Place the blister pack containing the vial adapter firmly on the vial top, piercing the vial. Push down gently until you feel it snap in place. Remove the blister pack from the vial adapter.

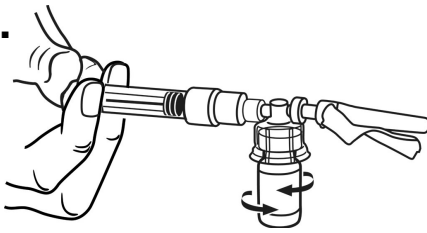
**4.** 

Keeping the plunger rod depressed, gently swirl the vial so that the diluent rinses the sides of the vial. This will ensure complete mixing of TRELSTAR® and the sterile water diluent. The suspension will now have a milky appearance. In order to avoid separation of the suspension, proceed to the next steps without delay.

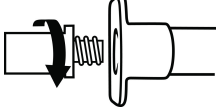
**2a.** 

(a) Screw the plunger rod into the barrel end of the syringe. Remove the cap from the syringe barrel.

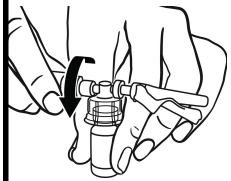
**2b.** 

(b) Connect the syringe to the vial adapter by screwing it clockwise into the opening on the side of the vial adapter. Be sure to gently twist the syringe until it stops turning to ensure a tight connection.

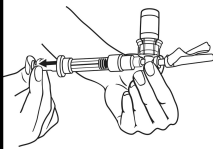
**5a.** 

(a) Invert the MIXJECT® system so that the vial is at the top. Grasp the MIXJECT® system firmly by the syringe and pull back the plunger rod slowly to draw the reconstituted TRELSTAR® into the syringe.

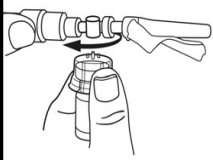
**5b.** 

(b) Return the vial to its upright position, and disconnect the vial adapter and vial from the MIXJECT® syringe assembly by turning the plastic cap of the vial adapter clockwise. *Grasp only the plastic cap when removing.*

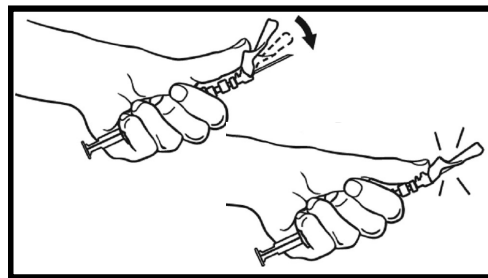
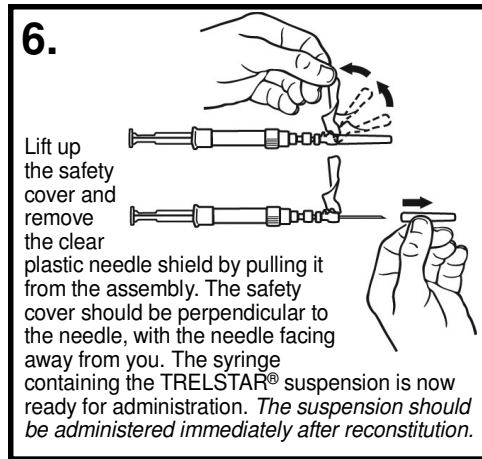
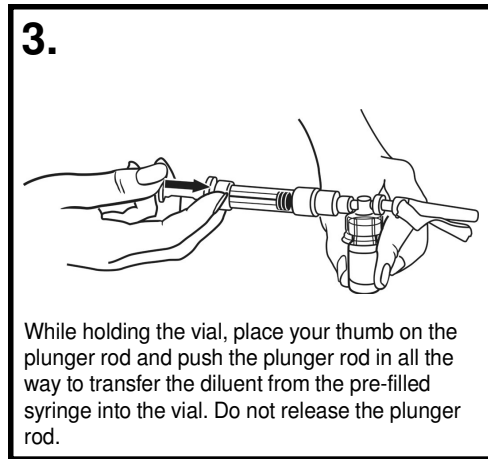

**MIXJECT® Disposal**

1. After administering the injection, immediately activate the safety mechanism by centering your thumb or forefinger on the textured finger pad area of the safety cover and pushing it forward over the needle until you hear or feel it lock. Use the one-handed technique and activate the mechanism away from yourself and others. Activation of the safety cover causes virtually no splatter.
2. Immediately discard the syringe assembly after a single use into a suitable sharps container.

**Instructions for Use – TRELSTAR™ vial (without Sterile Water for Injection)**

The lyophilized microgranules are to be reconstituted **in sterile water**. **No other diluent should be used**. It is necessary for an aseptic technique to be maintained throughout preparation.

**Preparation**

- 1) Using a syringe fitted with a sterile 21-gauge needle, withdraw 2 mL **sterile water** for injection, USP, and after removing the flip-off seal from the vial, inject into the vial.
- 2) Shake well to thoroughly disperse particles to obtain a uniform suspension. The suspension will appear milky.
- 3) Withdraw the entire content of the reconstituted suspension into the syringe and inject it immediately.

## **Disposal**

Dispose of the syringe and vial into a suitable sharps container.

## **OVERDOSAGE**

The pharmacologic properties of TRELSTAR™ (triptorelin pamoate for injectable suspension) and its mode of administration make accidental or intentional overdose unlikely. There is no experience of overdose from clinical trials. Acute animal toxicity of the drug is low and high multiples of clinical dose did not cause any adverse effects. If overdose occurs, it should be managed symptomatically.

## ACTION AND CLINICAL PHARMACOLOGY

TRELSTAR™ (triptorelin for injectable suspension) is a synthetic decapeptide agonist analog of naturally occurring luteinizing hormone-releasing hormone (LHRH), also called gonadotropin releasing hormone (GnRH). This analog possesses greater potency than the natural hormone.

Triptorelin acts as a potent inhibitor of gonadotropin secretion when given continuously in therapeutic doses. On administration of triptorelin there is an initial and transient increase in circulating levels of luteinizing hormone (LH), follicle-stimulating hormone (FSH), and estradiol. However, chronic and continuous administration of triptorelin results in decreased LH and FSH secretion and suppression of ovarian steroidogenesis. In premenopausal women, circulating estrogen is decreased to postmenopausal levels (Table 2). This results in accessory sexual organ atrophy which is generally reversible upon discontinuation of drug therapy.

	Week 0 Pretreatment	Week 4	Week 8	Week 12	Week 16	Week 20	Week 24
Mean	124	48	48	52	51	52	46
SD	77	42	36	37	35	36	25

A single intramuscular (IM) dose of 1.9, 3.75, or 7.5 mg to women with endometriosis, uterine myoma or dysfunctional bleeding resulted in transient dose-dependent increase in LH and estradiol following injection. By day 14, serum LH and estradiol concentrations decreased to levels typically seen in postmenopausal women. On day 28 and up to day 42 after injection, estradiol levels were still suppressed (<184 pmol/L) in the mid- and high-dose groups. Following LHRH challenge (100 mg) on day 28, 7/10 patients in the 1.9 mg group, 3/10 patients in the 3.75 mg group, and 0/10 patients in the 7.5 mg group responded to stimulation with increased LH levels. By day 56, estradiol concentrations returned to pretreatment levels in the mid-dose group but were still suppressed in the high dose group (7/8 patients).

### Pharmacokinetics

Results of pharmacokinetic investigations conducted in both women and men indicate that after IV bolus administration, triptorelin is distributed and eliminated according to a 3-compartment model with elimination from the central compartment and corresponding distribution half-lives of approximately 3 minutes, 47 minutes, and 5 hours in women and 6 minutes, 45 minutes, and 3 hours in men.

**Absorption:** Triptorelin is not active when given orally. Following a single intramuscular injection of the sustained release formulation in healthy male volunteers, mean peak triptorelin serum concentration was 28.4 ng/mL at 1-3 hours and 0.084 ng/mL at 4 weeks (Table 3). In this study, absolute bioavailability of intramuscular triptorelin relative to intravenous triptorelin (F based on AUC) was approximately 83%.

**TABLE 3. PHARMACOKINETIC PARAMETERS OF TRIPTORELIN FOLLOWING AN INTRAMUSCULAR ADMINISTRATION OF TRELSTAR™ IN HEALTHY MALE VOLUNTEERS**

(mean ± SD or median (range) for T<sub>max</sub>)

Triptorelin Pharmacokinetics				
No. of Subjects	C <sub>max</sub> (ng/mL)	T <sub>max</sub> (h)	AUC (h·ng/mL)	F (%)* (No. of days)
20	28.43 ± 7.31	1.0 (1.0 - 3.0)	223.15 ± 46.96	83 (28 d)

\* Computed as the mean AUC of the study divided by the mean AUC of healthy volunteers corrected for dose (AUC = 36.1 h·ng/mL; 500 µg IV bolus of triptorelin).

**Distribution:** The volume of distribution of triptorelin following IV administration of 0.5 mg triptorelin was approximately 30-33 L in healthy male volunteers and women with endometriosis.

**Metabolism:** Metabolites of triptorelin have not been determined in humans. However, human pharmacokinetic data suggest that C-terminal fragments produced by degradation are either completely degraded within tissues or are rapidly further degraded in plasma, or cleared by the kidneys.

**Excretion:** Triptorelin is eliminated by both the liver and the kidneys. Following IV administration of 0.5 mg triptorelin peptide to 6 healthy male volunteers with a creatinine clearance of 149.9 mL/min, 41.7% of the dose was excreted in urine as intact peptide with a total triptorelin clearance of 211.9 mL/min. This percentage increased to 62.3% in patients with liver disease who have a lower creatinine clearance (89.9 mL/min). It has also been observed that the non-renal clearance of triptorelin (patient anuric, Cl<sub>creat</sub>=0) was 76.2 mL/min, thus indicating that the nonrenal elimination of triptorelin is mainly dependant on the liver (see Special Populations).

Following a 0.5 mg IV bolus dose to 19 women, the total clearance was estimated to be 110 mL/min. Twenty percent of the dose was eliminated in the urine (Table 4).

**TABLE 4. PHARMACOKINETIC PARAMETERS FOLLOWING IV ADMINISTRATION OF TRIPTORELIN TO WOMEN WITH ENDOMETRIOSIS OR UTERINE MYOMA**

Dose (No. of subjects)	C <sub>max</sub> (ng/mL) <sup>1</sup>	T <sub>max</sub> (h) <sup>2</sup>	AUC (h·ng/mL) <sup>1</sup>	t <sub>1/2</sub> <sup>3</sup> (h) <sup>1</sup>	Cl <sub>p</sub> (mL/min) <sup>1</sup>	V <sub>ss</sub> (L) <sup>1</sup>	% elimin. Urine <sup>1</sup>
0.5 mg IVB (n=19)	115.8±59.0	0.03 (0.03-0.17)	81.9 ± 32.9	5.37 ±2.29	110 ± 40	32.9 ±16.8	20 ± 10

<sup>1</sup> Mean ± SD

<sup>2</sup> Median (range)

<sup>3</sup> Elimination half-life

### Special Populations:

*Renal and Hepatic Impairment:* After an IV injection of 0.5 mg triptorelin peptide, the two distribution half-lives were unaffected by renal and hepatic impairment, but renal insufficiency led to a decrease in total triptorelin clearance proportional to the decrease in creatinine clearance as well as an increase in volume of distribution and consequently an increase in elimination half-life (Table 5). The decrease in triptorelin clearance was more pronounced in subjects with liver

insufficiency, but the half-life was prolonged similarly in subjects with renal insufficiency, since the volume of distribution was only minimally increased.

**TABLE 5. PHARMACOKINETIC PARAMETERS (MEAN  $\pm$ SD) IN HEALTHY VOLUNTEERS AND SPECIAL POPULATIONS**

Group	C <sub>max</sub> (ng/mL)	AUC <sub>inf</sub> (h·ng/mL)	Cl <sub>p</sub> (mL/min)	Cl <sub>renal</sub> (mL/min)	T <sub>1/2</sub> (h)	Cl <sub>creat</sub> (mL/min)
6 healthy male volunteers	48.2 $\pm$ 11.8	36.1 $\pm$ 5.8	211.9 $\pm$ 31.6	90.6 $\pm$ 35.3	2.81 $\pm$ 1.21	149.9 $\pm$ 7.3
6 males with moderate renal impairment	45.6 $\pm$ 20.5	69.9 $\pm$ 24.6	120.0 $\pm$ 45.0	23.3 $\pm$ 17.6	6.56 $\pm$ 1.25	39.7 $\pm$ 22.5
6 males with severe renal impairment	46.5 $\pm$ 14.0	88.0 $\pm$ 18.4	88.6 $\pm$ 19.7	4.3 $\pm$ 2.9	7.65 $\pm$ 1.25	8.9 $\pm$ 6.0
6 males with liver disease	54.1 $\pm$ 5.3	131.9 $\pm$ 18.1	57.8 $\pm$ 8.0	35.9 $\pm$ 5.0	7.58 $\pm$ 1.17	89.9 $\pm$ 15.1

*Age and Race:* The effects of age and race on triptorelin pharmacokinetics have not been systematically studied. However, pharmacokinetic data obtained in young healthy male volunteers aged 20 to 22 years with an elevated creatinine clearance (approximately 250 mL/min) indicates that triptorelin was eliminated twice as fast in this young population (see Special Populations, Renal and Hepatic Impairment) as compared to patients with moderate renal insufficiency. This is related to the fact that triptorelin clearance is partly correlated to total creatinine clearance, which is well known to decrease with age.

## STORAGE AND STABILITY

Store TRELSTAR™ vial supplied with Clip'n'Ject® Dose Delivery System (with Sterile Water for Injection) at 20-25 °C (68-77 °F); excursions permitted: 15-30 °C (59-86 °F).

Store TRELSTAR™ vial supplied with MIXJECT™ Dose Delivery System (with Sterile Water for Injection) at 20-25 °C (68-77 °F); excursions permitted: 15-30 °C (59-86 °F).

Store TRELSTAR™ vial (without Sterile Water for Injection) at 4–25 °C (39-77 °F).

No refrigeration necessary. Protect from freezing. Protect from light.

Unused portion of reconstituted TRELSTAR™ should be discarded immediately.

## DOSAGE FORMS, COMPOSITION AND PACKAGING

TRELSTAR™ is supplied in a vial containing sterile lyophilized triptorelin pamoate microgranules which are equivalent to 3.75 mg triptorelin peptide base, incorporated in a biodegradable copolymer of lactic and glycolic acids. When 2 mL Sterile Water for Injection is added to the microgranules and mixed, a suspension is formed, which is intended as a single, monthly intramuscular injection.

**TRELSTAR™ is available in three presentations:**

**TRELSTAR™ dose delivery system (with Sterile Water for Injection), Clip'n'Ject®:**

Each TRELSTAR™ vial contains triptorelin pamoate (equivalent to 3.75 mg triptorelin), poly-d,l-lactide-co-glycolide (170 mg), mannitol, USP (85 mg), carboxymethylcellulose sodium, USP (30 mg), and polysorbate 80, USP (2 mg). The accompanying pre-filled syringe contains 2 mL Sterile Water for Injection.

**TRELSTAR™ dose delivery system (with Sterile Water for Injection), MIXJECT™:**

Each TRELSTAR™ vial contains triptorelin pamoate (equivalent to 3.75 mg triptorelin), poly-d,l-lactide-co-glycolide (170 mg), mannitol, USP (85 mg), carboxymethylcellulose sodium, USP (30 mg), and polysorbate 80, USP (2 mg). The accompanying pre-filled syringe contains 2 mL Sterile Water for Injection.

**TRELSTAR™ vial (without Sterile Water for Injection):**

Each TRELSTAR™ vial contains triptorelin pamoate (equivalent to 3.75 mg triptorelin), poly-d,l-lactide-co-glycolide (170 mg), mannitol, USP (85 mg), carboxymethylcellulose sodium, USP (30 mg), and polysorbate 80, USP (2 mg).

## PART II: SCIENTIFIC INFORMATION

### PHARMACEUTICAL INFORMATION

#### Drug Substance

**Proper Name:** Triptorelin pamoate  
**Chemical Name:** 5-Oxo-L-prolyl-L-histidyl-L-tryptophyl-L-seryl-L-tyrosyl-D-tryptophyl-L-leucyl-L-arginyl-L-prolylglycine amide, pamoate salt

**Structural Formula:**

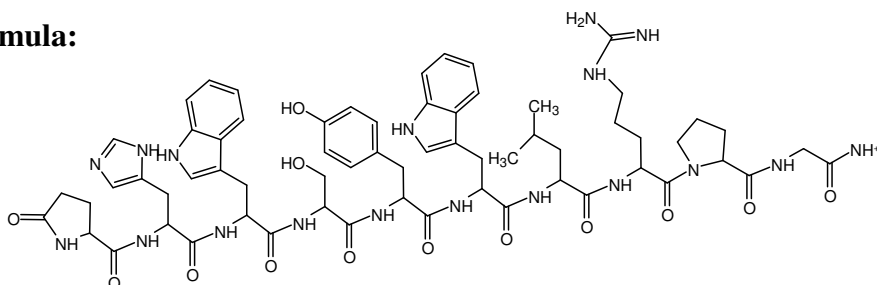

• Pamoic acid

**Molecular Formula:**  $C_{64}H_{82}N_{18}O_{13} \cdot C_{23}H_{16}O_6$

**Molecular Weight:** 1699.9

**Description:** Yellowish powder, specific optical rotation  $[\alpha]_D^{25} = -23.0^\circ \pm 2.5^\circ$

**Physicochemical properties:** Soluble in DMSO (660 mg/mL), pyridine (440 mg/mL) and water (60  $\mu$ g/mL)

## CLINICAL TRIALS

### Study Demographics and Trial Design

In a randomized, single-blind, clinical trial conducted in 137 women with clinically verified endometriosis comparing triptorelin (3.75 mg IM q4w x 6) with leuprolide (3.75 mg IM q4w x 6), triptorelin was shown to be comparable to leuprolide in relieving or reducing the clinical symptoms associated with endometriosis.

Fifty-five (55, 82%) patients in the triptorelin group and 57 (81%) in the leuprolide group completed the six-month treatment phase of the study. The clinical trial population consisted of 97.0% Caucasian and 3.0% Asian in the triptorelin treatment group, and 97.1% Caucasian, 1.4% Asian, and 1.4% Afro-Caribbean in the leuprolide treatment group. The mean patient age was 32 years in both treatment groups. The mean duration of endometriosis was the same (1.2 years, range 0-11) in both groups, and a similar percentage of patients in both groups had minimal, mild, and moderate disease at pre-treatment laparoscopy.

## **Study Results**

The primary objective of the study was to demonstrate the equivalence of triptorelin and leuprolide, both as 1-month formulations, in terms of reduction in the pelvic pain associated with endometriosis. Reduction of pelvic pain was based on end-of-treatment versus baseline physician ratings for pelvic pain severity (six categories ranging from 0=absent to 5=excruciating). Other efficacy evaluations included endocrine blood levels (FSH, LH, E<sub>2</sub>), breakthrough bleeding assessment, and pelvic examinations. Safety evaluations included collection of adverse events, hematology and blood chemistry laboratory testing, and bone mineral density testing in a subset of the population (approximately 60 patients).

Of the women who participated in the study, 80% showed reduction in pelvic pain, 100% showed reduction in dysmenorrhea, and 66% showed reduction in dyspareunia from baseline after 6 months of triptorelin therapy. Serum estradiol levels were suppressed (<184 pmol/L) by 4 weeks, and were maintained at suppressed levels for the remainder of the 6 month treatment period. The range of estradiol levels attained at 6 months (24 weeks) of therapy was 17 – 128 pmol/L. By 12 weeks, most women (90%) also became amenorrheic in response to the low levels of estrogen. Once treatment ended, the mean time to return to menses was 81 days (range: 6 – 116). Estrogen levels returned to baseline values by 3 months post treatment.

As shown in Table 6, over 40% of patients in each treatment group were completely free of pelvic pain, over 95% in each group were completely free of dysmenorrhea, and over 80% in each group were free of dyspareunia after 6 months of therapy. After 12 months of follow-up similar percentages of women in each treatment were still free of the pain symptoms associated with endometriosis.

<b>TABLE 6. PROPORTION OF PATIENTS FREE OF PAIN SYMPTOMS</b>				
<b>Pain Symptom</b>	<b>Triptorelin (n=66) 3.75 mg IM q4w x6</b>		<b>Leuprolide (n=70) 3.75 mg IM q4w x6</b>	
	<b>6 months of therapy</b>	<b>12 months follow-up</b>	<b>6 months of therapy</b>	<b>12 months follow-up</b>
Pelvic Pain	42% (23/55) <sup>1</sup>	27% (9/33)	46% (27/59)	27% (9/33)
Dysmenorrhea	96% (53/55)	16% (5/32)	98% (58/59)	22% (7/32)
Dyspareunia	82% (45/55)	70% (23/33)	81% (48/59)	64% (21/33)

<sup>1</sup> Numbers in parenthesis reflect the proportion of patients without pain symptoms over the total number of patients still in the study at that assessment visit.

## DETAILED PHARMACOLOGY

Triptorelin is a potent agonist of LHRH. The potency relative to native LHRH has been demonstrated both *in vitro* and *in vivo*. Comparative *in vitro* studies showed that triptorelin was 100-fold more active than native LHRH in stimulating LH release from monolayers of dispersed rat pituitary cells in culture and 20-fold more active than native LHRH in displacing <sup>125</sup>I-LHRH from pituitary receptor sites. The increased potency was correlated with an increased resistance to degradation on exposure to enzyme preparations derived from rat hypothalamus or anterior pituitary. *In vivo* studies in immature male rats showed that triptorelin had 13-fold higher LH-releasing activity and 21-fold higher FSH-releasing activity compared to native LHRH. Compared with the ovulating-inducing capacity of native LHRH in adult Sprague-Dawley rats and Swiss albino mice, triptorelin was 84-fold more potent in proestrus rats (pretreated with fluphenazine to block ovulation), 372-fold more potent in pregnant rats, 85-fold more potent in diestrus rats, and 63-fold more potent in diestrus mice.

A series of experiments showed that long-term administration of triptorelin inhibited prostate cancer growth in male rats that had been inoculated subcutaneously with Segaloff 11095 rat prostate tumor, a chemically-induced, androgen-dependent squamous cell carcinoma; in male rats bearing Dunning R3227 rat prostate tumor, a spontaneous androgen-dependent adenocarcinoma with characteristics similar to human prostate adenocarcinoma; in male rats bearing an androgen-independent Dunning R3327\_AT\_1 prostate tumor; and in male nude mice bearing xenografts of the hormone-dependent human prostatic tumor PC-82.

In both rats and human prostate tumors, two classes of binding sites were found for triptorelin, one with high affinity and low binding capacity and the other with low affinity and high binding capacity. In rats with prostate tumors, chronic treatment with triptorelin produced down-regulation of membrane receptors for LHRH in the tumors. Additionally, direct antiproliferative effects of LHRH agonists were demonstrated *in vitro* for both androgen-independent Dunning R3327-AT-1 rat prostate cancer cells and androgen-sensitive human LNCaP prostatic cancer cells.

In male rats, chronic administration of triptorelin caused a decrease in weights of testes, seminal vesicles, and prostate; a fall in blood testosterone levels; inhibition of spermatogenesis; and a reduction of testicular LH/hCG and PRL receptors. Experiments in hypophysectomized animals showed that some of these effects result from the direct action of triptorelin on testicular LH receptors. In both adult and immature hypophysectomized male rats, daily injections of 2 µg triptorelin for 7 days decreased the number of testicular LH/hCG binding sites. The effects of triptorelin on testicular LH receptors were biphasic and could be nullified by LHRH antagonists. In hypophysectomized adult male rats primed with pregnant mare serum, daily administration of 200 ng triptorelin reduced the number of testicular LH receptors to 60% of control values, but a 1 ng dose increased receptors to 485% of control values. Both effects were nullified when an antagonist was administered concomitantly with triptorelin.

In female rats, chronic administration of triptorelin or other LHRH agonists caused a delay in vaginal opening, reduction in ovarian and uterine weight; interference with implantation and termination of gestation; and a decrease in the number of ovarian receptors for LH/hCG.

## **TOXICOLOGY**

### **Acute Toxicity Studies**

In acute toxicity studies, no clinical symptoms were observed in either mice or rats with single doses up to 10 mg/kg triptorelin.

### **Subchronic and Chronic Toxicity Studies**

In subchronic and chronic toxicity studies of triptorelin, triptorelin acetate microspheres, and triptorelin pamoate microgranules in rats, beagle dogs, and monkeys, the only effects observed were expected consequences of the physiologic action of the drug. Serum levels of testosterone (in males), estradiol and progesterone (in females), and LH were suppressed in animals (rats, dogs, monkeys) administered 2 µg/kg/day and higher doses of triptorelin by daily injection or administered the equivalent average daily dose by once monthly intramuscular injection of a sustained release formulation (triptorelin acetate microspheres or triptorelin pamoate microgranules). At the same dose levels, spermatogenic arrest and atrophy of the testes and accessory sex organs were observed in male animals (rats, dogs, monkeys) and inhibition of estrus and atrophy of the ovary and accessory sex organs were observed in female animals (rats, dogs, monkeys). In both males and females, triptorelin caused decreases in weights of reproductive organs. Changes in the anterior pituitary (focal hyperplasia and benign microadenoma) were detected in male rats administered once monthly injections of triptorelin acetate microspheres or daily injection of triptorelin peptide for 6 months; these changes are commonly observed in rats in response to an altered hormonal environment. No changes were observed in the pituitary in dogs or monkeys after 6 months of drug administration.

On withdrawal of the drug, changes in serum hormones, reproductive organ weights, and microscopic atrophic changes in the gonads and accessory sex organs were reversible. Pituitary hyperplasia and benign microadenoma were not reversible.

### **Carcinogenicity Studies**

Carcinogenicity studies of triptorelin were performed in mice and rats. No oncogenic effects were observed in mice given from 120 to 6000 µg/kg triptorelin pamoate microgranules every 28 days for 18 months. An oncogenic effect in the pituitary gland (adenoma of the pars distalis) which resulted in premature deaths was observed in rats given from 120 to 3000 µg/kg triptorelin pamoate depot formulation every 28 days for 23 months. Changes in the anterior pituitary (focal hyperplasia and microadenoma) were judged to be related to the intrinsic pharmacologic activity of the drug. Similar changes in the anterior pituitary of male rats given triptorelin over a 6 month period had been observed in a chronic toxicity study in male rats.

## **Reproduction Studies**

Developmental toxicity studies of triptorelin were performed in mice and rats. No maternal toxicity, fetal toxicity, or embryotoxic or teratogenic effects were observed when pregnant female mice were given daily subcutaneous injections of 2 to 200 µg/kg triptorelin on days 6 through 15 of gestation. No maternal toxicity, fetal toxicity, or embryogenic or teratogenic effects were observed when pregnant female rats were given daily subcutaneous injections of 10 µg/kg triptorelin on days 6 through 15 of gestation. However, maternal toxicity, demonstrated by reduced weight gain during the treatment period, and an embryotoxic effect, demonstrated by an increase in uterine resorption, were observed when pregnant female rats were given daily subcutaneous injections of 100 µg/kg triptorelin on days 6 through 15 of gestation.

**Impairment of Fertility:** After about 6 months of treatment with triptorelin, atrophy of the genital organs, consistent with reduced fertility, was observed in rats and monkeys at doses ranging from 2 to 2,100 µg/kg. These changes were considered to be a reflection of the suppressed gonadal function caused by the pharmacologic activity of the drug. These effects were largely reversed during a 2 or 4 month recovery period. Testicular changes have also been reported after prolonged administration of triptorelin in patients with prostate cancer.

## **Mutagenicity Studies**

The mutagenicity of triptorelin was assessed *in vitro* and *in vivo*. Triptorelin showed no mutagenic or clastogenic activity against Salmonella strains, Chinese Hamster Ovary (CHO) cells, and mouse lymphoma cells, under either metabolic activation or non-activation conditions. In the *in vivo* mouse micronucleus assay, triptorelin-treated animals showed no significant increase in micronucleus frequency compared to negative control, whereas the known clastogenic agent cyclophosphamide induced large and statistically significant increases in micronucleus frequency.

## **REFERENCES**

1. Adamopoulos DA, Nicopoulou S, Kapolla N, Vassilopoulos P, Keramertzanis M: Testicular secretion after pulsatile human menopausal gonadotropin therapy in gonadotropin-releasing hormone agonist desensitized dysspermic men. *Fertil Steril* 62:155-161, 1994.
2. Banik UK, Givner ML. Comparative ovulation-inducing capacity of a synthetic luteinizing hormone-releasing hormone and two analogs in adult rats and mice. *Fertil Steril* 11:1243-1249, 1977.
3. Barron JL, Millar RP, Searle D: Metabolic clearance and plasma half-disappearance time of D-Trp<sup>6</sup> and exogenous luteinizing hormone-releasing hormone. *J Clin Endocrinol Metab* 54: 1169-1173, 1982.
4. Bergqvist A, Bergh T, Hogstrom L, et al: Effects of triptorelin versus placebo on the symptoms of endometriosis. *Fertil Steril* 69:702-708, 1998.

5. Boccardo FA, Decensi D, Guarneri A, Rubagotti T, Massa G, Martorana C et al: Long-term results with a long-acting formulation of D-Trp<sup>6</sup>LH-RH in patients with prostate cancer: an Italian prostatic cancer project study (P.O.N.C.A.P.). *Prostate* 11: 243-255, 1987.
6. Choktanasiri W, Boonkasemsanti W, Sittisomwong T, Kunathikom S, Suksompong S, Udomsubpayakul U, et al: Long-acting triptorelin for the treatment of endometriosis. *Int J Gynecol Obstet* 54:237-243, 1996.
7. Cirkel V, Ochs H, Schneider HPG: A randomized comparative trial of triptorelin depot (D-Trp<sup>6</sup>-LHRH) and danazol in the treatment of endometriosis. *Eur J Obst Gynec Reprod Biol* 59:61-9; 1995.
8. Coy DH, Labrie F, Savary M, Coy EJ, Schally AV. *LH-releasing activity of potent LH-RH analogs in vitro.* *Biochem Biophys Res Commun* 67:576-582, 1975.
9. Coy DH, Vilchez-Martinez JA, Coy EJ, Schally AV. Analogs of luteinizing hormone-releasing hormone with increased biological activity produced by D-amino acid substitutions in position 6. *J Med Chem* 19:423-425, 1976.
10. De Sy WA, De Wild P, De Meyer JM, Casselman J, Desmet R, Renders G, Schelfhout W. Long term experience in the *treatment of prostatic cancer with Decapeptyl<sup>®</sup>, compared to orchiectomy.* *Acta Urologica Belgica* 56:581-588, 1986.
11. De Sy WA, De Meyer JM, Casselman J, De Smet R, Renders G, Schelfhout W, De Wild P. A comparative study of a long acting leuteinizing hormone releasing hormone agonist (Decapeptyl<sup>®</sup>) and orchiectomy in the treatment of advanced prostate cancer. *Acta Urologica Belgica* 54:221-229, 1988.
12. Emons G, Iven H, K pker W, Schally A: Bioavailability of Decapeptyl-Depot ([D-Trp<sup>6</sup>] GnRH) in women. *Arch Gynecol Obstet* 250:1035-1036, 1991.
13. Filicori M, Flamigni C, Cognigni G, Dellai P, Arnone R, Falbo A, Capelli M: Comparison of the suppression capacity of different depot gonadotropin-releasing hormone analogs in women. *J Clin Endocrinol Metab* 77:130-133, 1993.
14. Gonzalez-Barcena D, Perez-Sanchez PL, Graef A, Gomez AM, Barea H, et al. Inhibition of the pituitary-gonadal axis by a single intramuscular administration of D-Trp<sup>6</sup>-LHRH (Decapeptyl<sup>®</sup>) in a sustained release formulation in patients with prostatic carcinoma. *Prostate* 14: 291-300, 1989.
15. Jacobi GH, Wenderoth UK, Ehrenthal W, v Wallenberg H, Spindler HW, Hohenfellner R: Endocrine and clinical evaluation of 107 patients with advanced prostatic carcinoma under long-term pernasal buserelin or intramuscular Decapeptyl<sup>®</sup> depot treatment. *Am J Clin Oncol* 11(suppl 1): S36-S43, 1988.
16. Mason-Garcia M, Vigh S, Comaru-Schally AM, Rading TW, Somogyvari-Vigh SA, Horvath J et al. Radioimmunoassay for 6-D-tryptophan analog of luteinizing hormone-releasing hormone: measurement of serum levels after administration of long-acting formulation administration. *Proc Natl Acad Sci USA* 82:1547-1551, 1985.

17. Milovanovic SR, Radulovic S, Groot K, Schally AV. Inhibition of growth of PC-82 human prostate cancer line xenografts in nude mice by bombesin antagonist RC-3095 or combination of [D-Trp<sup>6</sup>]-luteinizing hormone-releasing hormone and somatostatin analog RC-160. *Prostate* 20:269-280, 1992.
18. Papadopoulos I, Merkel KH, Cramer B, Weissach L. Hodenhistologie nach 6monatiger therapie mit der depotform des LHRH-analogons Decapeptyl<sup>®</sup>. *Verh Deutsch Geselle Urologie* 38:274-277, 1987.
19. Parmar H, Edwards L, Phillips RH, Allen L, Lightman SL. Orchiectomy versus long-acting D-Trp-6-LHRH in advanced prostatic cancer. *Br J Urol* 1987; 59:248-4
20. Redding TW, Schally AV. Inhibition of prostate tumor growth in two rat models by chronic administration of [D-Trp<sup>6</sup>] analogue of luteinizing hormone-releasing hormone. *Proc Natl Acad Sci USA* 78:6509-6512, 1981.
21. Redding TW, Schally AV, Tice TR, Meyers WE. Long-acting delivery systems for peptides: Inhibition of rat prostate tumors by controlled release of [D-trp<sup>6</sup>] luteinizing hormone-releasing hormone from injectable microcapsules. *Proc Natl Acad Sci USA* 81:5845-5848, 1984.
22. Roger M, Duchier J, Lahlou N, Nahoul K, Schally AV: Treatment of prostatic carcinoma with D-Trp-6-LHRH: plasma hormone levels after daily subcutaneous injections and periodic administration of delayed-release preparations. *The Prostate* 7:271-82, 1985.
23. Schally AV, Redding TW. Somatostatin analogs as adjuncts to agonists of luteinizing hormone-releasing hormone in the treatment of experimental prostate cancer. *Proc Natl Acad Sci USA* 84:7275-7259, 1987.
24. Schally AV, Redding TW, Comaru-Schally AM. Inhibition of prostate tumors by agonistic and antagonistic analogs of LH-RH. *Prostate* 4:545-552, 1983.
25. Stoffel-Wagner B, Sommer L, Bidlingmaier F, Klingmiller D: Effects of the gonadotropin-releasing hormone agonist, D-Trp-6-GnRH, on prolactin secretion in healthy young men. *Horm Res* 43:266-272, 1995.
26. The Veterans Administration Cooperative Urological Research Group. Carcinoma of the Prostate: Treatment Comparisons. *J Urol* 98:516-522, 1967.
27. Walker KJ, Turkes AO, Nicholson RI, Turkes A, Griffiths K. Therapeutic potential of the LHRH agonist ICI 118630 in the treatment of advanced prostatic carcinoma. *Lancet* 413-145; 20 August, 1983.
28. Zorn JR, Mathieson J, Risquez F, Comaru-Schally AM, Schally AV: Treatment of endometriosis with a delayed release preparation of the agonist D-Trp<sup>6</sup>-luteinizing hormone-releasing hormone: long-term follow-up in a series of 50 patients. *Fertil Steril* 53:401-406, 1990.

**FOR THE MANAGEMENT AND RELIEF  
OF CHRONIC PAIN  
ASSOCIATED WITH ENDOMETRIOSIS**

**PART III: CONSUMER INFORMATION**

**Pr TRELSTAR™**

Triptorelin Pamoate for Injectable Suspension

**This leaflet is part III of a three-part "Product Monograph" published when TRELSTAR™ was approved for sale in Canada and is designed specifically for Consumers. This leaflet is a summary and will not tell you everything about TRELSTAR™. Contact your doctor or pharmacist if you have any questions about the drug.**

**ABOUT THIS MEDICATION**

TRELSTAR™ belongs to a class of drugs called gonadotropin-releasing hormone (GnRH) agonists.

**What the medication is used for:**

Your doctor has prescribed TRELSTAR™ to treat your endometriosis. Endometriosis is a disease in which abnormal tissue grows in the abdomen and other places in the body. It can be treated with pain medication, hormones and surgery.

**What it does:**

TRELSTAR™ works like a hormone and reduces the level of estrogen in your body. A reduction in the level of your estrogen may help reduce the pain and other symptoms of endometriosis. The duration of your treatment will be up to 6 months. Once you stop treatment, the level of estrogen will return to normal. Even though you will be stopping treatment after 6 months, you will still benefit from the treatment for many months afterwards.

**When it should not be used:**

TRELSTAR™ should not be used if:

- You are allergic or oversensitive to triptorelin, or to drugs called LHRH agonists, or to any ingredients in the formulation or component of the vial.
- You are or may become pregnant, or if you are nursing. In pregnant women, TRELSTAR™ may cause harm to the baby.
- You have abnormal vaginal bleeding that has not been checked by your doctor.
- You are a woman under 18 years of age. TRELSTAR™ was not studied in children.

**What the medicinal ingredient is:**

Triptorelin pamoate

**What the nonmedicinal ingredients are:**

Poly-d,l-lactide-co-glycolide, mannitol, carboxymethylcellulose sodium and polysorbate 80.

**What dosage forms it comes in:**

TRELSTAR™ is a sterile powder stored in a vial. The powder will be mixed by your doctor with sterile water to make a suspension before injecting it into your muscle. The active ingredient contained in the microgranules will slowly be released from the injection site.

TRELSTAR™ contains 3.75 mg of triptorelin.

**WARNINGS AND PRECAUTIONS**

**BEFORE you use TRELSTAR™ talk to your doctor or pharmacist if:**

- You have any allergies to this drug, or its ingredients, or to components of the vial
- You think you may be pregnant
- You are nursing
- You have a history of chronic alcohol and/or tobacco use
- You have a strong family history of osteoporosis
- You have a history of chronic use of drugs such as anticonvulsants or corticosteroids.
- You have kidney and/or liver disease

Since menstruation (your period) should stop while you are on TRELSTAR™ treatment, you should tell your doctor if regular menstruation continues.

Before beginning treatment with TRELSTAR™, your doctor should have you take a test to ensure that you are not pregnant.

You may experience breakthrough bleeding or ovulation if you miss one or more doses of TRELSTAR™. Because of the risk to a baby should you become pregnant while on TRELSTAR™ treatment, it is important to use a nonhormonal method of contraception. If you suspect you might be pregnant, consult your doctor immediately. Your treatment should be discontinued.

You should know how TRELSTAR™ affects you before driving a vehicle or operating machinery.

**INTERACTIONS WITH THIS MEDICATION**

Before your treatment with TRELSTAR™, check with your doctor or pharmacist before taking any other drugs, including nonprescription drugs (for colds, nausea, etc). During your treatment with TRELSTAR™ do not start taking a new medicine before checking with your doctor or pharmacist.

**PROPER USE OF THIS MEDICATION**

**How is TRELSTAR given?**

**Usual Dose:**

Your doctor will administer one injection of TRELSTAR™, containing 3.75 mg triptorelin, into your muscle on a specified day, generally once every 28 days, for a period of 6 months.

**Missed Dose:**

If you forget to have TRELSTAR™ administered on the specified day, have it administered as soon as you can.

It is very important that your doctor check your progress at regular medical visits. Don't stop your TRELSTAR™ treatment if you feel better; consult your doctor before you decide to change your treatment.

### SIDE EFFECTS AND WHAT TO DO ABOUT THEM

Like all medicines, TRELSTAR™ may have, in addition to its beneficial effects, some unwanted effects.

TRELSTAR™ treatment, given once a month, results in suppression of your sex hormones. Any effects you experience may be related to this hormone-suppressing action of TRELSTAR™. These effects may include hot flushes, reduction in sex drive, headaches, emotional changes, acne, reduction in breast size and vaginal dryness\*. If these continue to make you feel uncomfortable, consult your doctor. Since estrogen levels return to normal after treatment is discontinued, these effects should disappear.

Occasionally, a local skin reaction may occur at the injection site such as itching, redness, burning and swelling. These reactions generally are mild and disappear after a few days. If they get worse or do not go away, tell your doctor.

Consult your doctor immediately if you develop severe or increased pain, numbness or weakness of the limbs, or persistent difficulty in urinating.

Other side effects not listed above may also occur in some patients. If you notice any other effects, tell your doctor immediately.

### SERIOUS SIDE EFFECTS, HOW OFTEN THEY HAPPEN AND WHAT TO DO ABOUT THEM

Symptom / effect	Talk with your doctor or pharmacist		Stop taking drug and call your doctor or pharmacist
	Only if severe	In all cases	
<b>Common</b>			
Nausea		✓	
Viral infection		✓	
Pain		✓	
Abdominal pain		✓	
Back pain		✓	
Joint pain		✓	
Lower abdominal pain		✓	
Bruising		✓	
Dizziness		✓	
Infection of bladder and/or kidneys		✓	
Tiredness		✓	
Vomiting		✓	
<b>Uncommon</b>			
Pain		✓	
Acute abdominal pain		✓	
Chest pain		✓	
Muscle pain		✓	
Injection site reaction		✓	
Rash		✓	
Swelling in the limbs		✓	
Leg cramps		✓	
Diarrhea		✓	
Constipation and diarrhea		✓	
Joint disease		✓	
Memory loss		✓	
Lack of interest or concern		✓	
Yellow/pale discharge from vagina		✓	
Severe bleeding from vagina		✓	

\* Are considered expected side effects related to the hormone-suppressing action of TRELSTAR™

This is not a complete list of side effects. For any unexpected effects while taking TRELSTAR™, contact your doctor or pharmacist.

### HOW TO STORE IT

Store TRELSTAR™ vial supplied with Clip'n'Ject® Dose Delivery System (with Sterile Water for Injection) at 20-25°C (68-77°F); excursions permitted: 15 – 30°C (59-86°F).

Store TRELSTAR™ vial supplied with MIXJECT™ Dose Delivery System (with Sterile Water for Injection) at 20-25°C (68-77°F); excursions permitted: 15 – 30°C (59-86°F).

Store TRELSTAR™ vial (without Sterile Water for Injection) at 4 - 25°C (39-77°F).

No refrigeration is necessary. Protect from freezing. Protect from light.

Keep out of reach of children.

### SERIOUS SIDE EFFECTS, HOW OFTEN THEY HAPPEN AND WHAT TO DO ABOUT THEM

Symptom / effect	Talk with your doctor or pharmacist		Stop taking drug and call your doctor or pharmacist
	Only if severe	In all cases	
<b>Common</b>			
Hot flushes*	✓		
Vaginal dryness*	✓		
No menstrual periods		✓	
Increased sweating		✓	
Difficulty falling asleep		✓	
Headache*	✓		
Depression		✓	
Decreased sex drive*	✓		
Emotional changes/irritability*	✓		
Dandruff		✓	
Reduction in breast size*	✓		
Acne*	✓		
Ankle swelling		✓	

(continued)

**REPORTING SUSPECTED SIDE EFFECTS**

To monitor drug safety, Health Canada collects information on serious and unexpected effects of drugs. If you suspect you have had a serious or unexpected reaction to this drug you may notify Health Canada by:

toll-free telephone: 866-234-2345

toll-free fax: 866-678-6789

By email: [cadrmp@hc-sc.gc.ca](mailto:cadrmp@hc-sc.gc.ca)

By regular mail:

Canadian Adverse Reaction Monitoring Program  
(CADRMP)

Marketed Health Products Safety and Effectiveness  
Information Division

Marketed Health Products Directorate

Tunney's Pasture, AL 0701C

Ottawa ON K1A 0K9

*NOTE: Before contacting Health Canada, you should contact your physician or pharmacist.*

**MORE INFORMATION**

This document plus the full product monograph, prepared for health professionals, can be found by contacting the Distributor, Paladin Labs Inc., at 1-888-550-6060.

This leaflet was prepared by:

Watson Laboratories, Inc.

Corona, California

USA 92880

Distributed in Canada by:

Paladin Labs Inc.

Montreal, Quebec H4P 2T4

Date of Preparation: August 2008